

Small Filter Housings

VF-31E

Clean Dry Fuels with High Performance

Aquacon® Filter Cartridges

FEATURES:

- Free and emulsified water to less than 5 ppm
- 1/2 micrometer particulate removal
- Provides protection against “slugs” of water
- Pressure increase signals cartridge change
- Use with existing filter housings

APPLICATIONS

- Kerosene
- Diesel
- Biodiesel
- Gasoline

NOTE: For non-EI qualified applications. Housing does not meet EI1596 or EI1581 qualifications.



VF-31E
Filter Housing



AC-21005
Filter Cartridge



ACA-210
Filter Cartridge

DESCRIPTION

The VF-31E is a versatile filter housing designed for use with several different high performance **Aquacon** filter cartridges. Cartridges are offered for the optimum filtration of aviation fuel (see caution on reverse side), gasoline, diesel fuel, oils, compressed air, and other gasses. Refer to the Cartridge Selection Table for details.

Aquacon filters eliminate water contamination problems by

removing water from fuels, oils, and gasses. Filtered water is chemically locked into the cartridge's inner super-absorbent media.

As a cartridge reaches its water holding limit, the media expands very rapidly and restricts the flow of unfiltered material. This causes an increase in the differential pressure which signals the operator to replace the cartridge. When filtering fuels or compressed air, a saturated Aquacon cartridge

will completely block the flow until it is replaced.

Aquacon cartridges are also excellent dirt filters. Silt, rust, and other particulates are removed by the cartridge's outer filter media. One-half, five, and 25 micron rated cartridges are available for use with fuels and oils. The ACA-210 cartridge, for use with compressed air and other gasses, has a 1 micron rating.

DIMENSIONS:

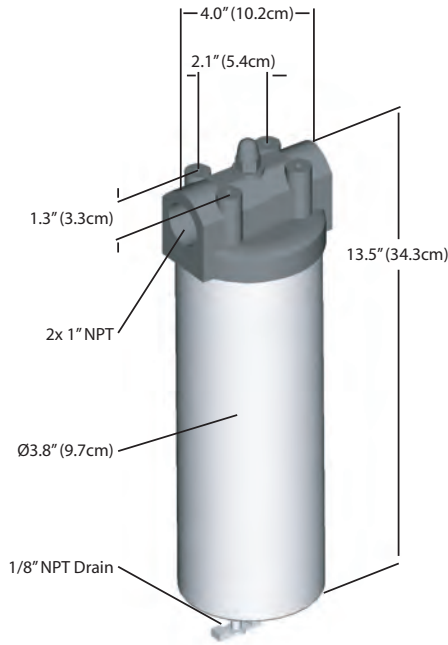

Dimensions are for estimating purposes only.

CAUTION

Do not use **Aquacon** absorbent cartridges (AC, ACO or AD Series) with pre-mixed jet fuel containing anti-icing additives, or with gasoline/alcohol blends.

SPECIFICATION:

- Maximum operating pressure: 150 psi
- Material: cast aluminum head, carbon steel bowl with TGIC-Polyester coated interior and exterior
- Inlet/Outlet Connection: 1" NPT
- Inlet/Outlet face-to-face: 4"
- Mounting holes in head: four 1/4-20 NC
- Seal: Buna-N gasket
- Height: 13.50" without Petcock, 14.50" with Petcock
- Weight: 3 lbs., 15 oz.
- Shipping Weight: 4 lbs., 15 oz.
- Hardware included: 1 ea. Buna-N Lid Gasket, Mounting Brackets, 1 ea. Plug (for fuel and oil applications), and 1 ea. 1/8" Petcock Drain (for air, gas and aviation fuel applications).

ORDERING INFORMATION

- Supplied without cartridge
- Supplied with 1 ea. Model G-0995 Buna-N Lid Gasket, Mounting Brackets, 1 ea. Plug, and 1 ea. 1/8" Drain Petcock

RECOMMENDED SPARES

- 1 ea. Model G-0995 Buna-N Lid Gasket
- 4 ea. filter cartridges (Specify from table.)

FILTER CARTRIDGE SELECTION TABLE

Product being filtered	Application	Cartridge P/N	Data Sheet	Type	Micron	Flow Rate (GPM)
Jet Fuel & Avgas ⁽¹⁾	Dirt & Free water	ACO-21001R	1681	Aquacon [®]	0.5	1-15
Motor Gasoline		AC-21005	1582		5	
Gasohol	Dirt	FOG-21005	N/A	Paper filter	5	1-15

(1) If system pressure can exceed 25 psi, always install pressure gauge or other means of determining differential pressure.

(2) See Data Sheet VEL1709 for absorbent cartridge (AC, AD) flow rates.